

FEMALE END VIEW

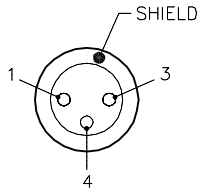

1 = BROWN
3 = BLUE
4 = BLACK



SPECIFICATIONS

CONTACT CARRIER MATERIAL/COLOR	NYLON OR TPU/BLACK
MOLDED HEAD MATERIAL/COLOR	TPU/YELLOW
CONTACT MATERIAL/PLATING	BRASS/GOLD
COUPLING NUT MATERIAL/PLATING	BRASS/NICKEL
RATED CURRENT [A]	4.0 A
RATED VOLTAGE [V]	125 VAC/VDC
OUTER JACKET MATERIAL/COLOR	TPU/BLACK
CONDUCTOR INSULATION MATERIAL	PVC
NUMBER OF CONDUCTORS [AWG]	3x24 AWG
DRAIN/SHIELD	26 AWG/ALUM.-POLYESTER FOIL, T-C BRAID
TEMPERATURE RANGE	-40°C to +90°C (-40°F to +194°F)
PROTECTION CLASS	MEETS IEC IP67

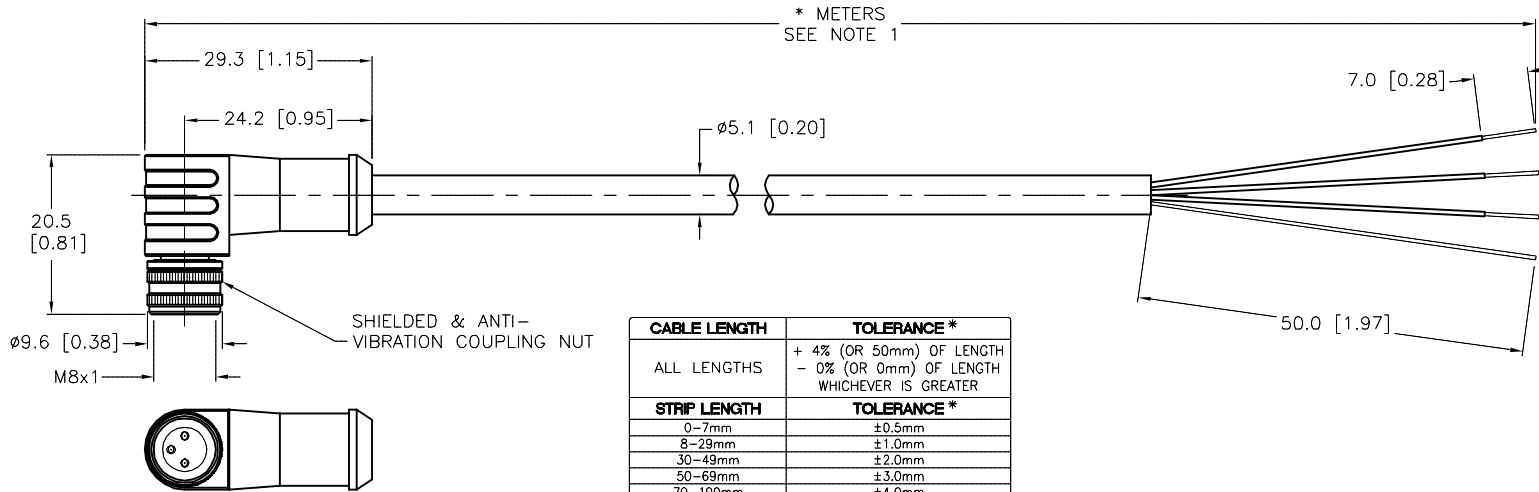

CABLE LENGTH	TOLERANCE *
ALL LENGTHS	+ 4% (OR 50mm) OF LENGTH - 0% (OR 0mm) OF LENGTH WHICHEVER IS GREATER
STRIP LENGTH	TOLERANCE *
0-7mm	±0.5mm
8-29mm	±1.0mm
30-49mm	±2.0mm
50-69mm	±3.0mm
70-100mm	±4.0mm
OVER 100mm	±5.0mm

* UNLESS OTHERWISE SPECIFIED

SOURCE DRAWING - FOR REFERENCE ONLY

NOTES:

- "*" INDICATES CABLE LENGTH IN METERS. CONTACT TURCK TO ORDER SPECIFIC LENGTHS.
- "/S90" DESIGNATES THERMOPLASTIC POLYURETHANE (TPU) CABLE JACKET.

RELATED DOCUMENTS		3RD ANGLE PROJECTION		THIS DRAWING IS CONFIDENTIAL AND THE PROPERTY OF TURCK INC. USE OF THIS DOCUMENT WITHOUT WRITTEN PERMISSION IS PROHIBITED.		TURCK INC High Technology Sensors and Automation Controls 3000 CAMPUS DRIVE MINNEAPOLIS, MN 55441 1-800-544-7769 (763) 553-7300 (763) 553-0708 fax turck.com	
1.			DRFT	RDS	DATE	04/08/08	DESCRIPTION PKWS 3M-*/S90
2.			DSGN		SCALE	1=1.0	
3.		ALL DIMENSIONS DISPLAYED ON THIS DRAWING ARE FOR REFERENCE ONLY CONTACT TURCK FOR MORE INFORMATION	UNIT OF MEASUREMENT		IDENTIFICATION NO.		REV
4.			MILLIMETER [INCH]				E
MATERIAL		SEE SPECIFICATIONS		DO NOT SCALE THIS DRAWING		FILE: 777016228	
FINISH		SEE SPECIFICATIONS		SHEET 1 OF 1			

E	DRAWING PROCESSED AS PART OF ECO 33971	CBM	04/06/11	33971
REV	DESCRIPTION	BY	DATE	ECO NO.